



Automatic Biological Reader User Manual

Model: BIOPT1 MINI

LISTER BIOMEDICAL CO.,LTD

www.listerbiomed.com

Preface

Dear user:

Hello! Thank you for choosing our company's product. In order for you to use the Automatic Bio Reader quickly and correctly, please carefully read the entire user manual, especially the sections concerning safety provisions.

If you have already read the entire user manual, we recommend that you keep this user manual properly, either with other relevant documents or in a place where you can access it at any time, for your reference during use.

Disclaimer

The data and illustrations listed in this user manual are for reference and explanation purposes only. The monitoring results, display, and printed materials of the equipment are for reference only and should not be used for clinical or maintenance assessments.

Optimization updates may be made to the Automatic Bio Reader software or hardware without further notice. The system images, hardware components, and hardware specifications contained in the user manual may not be consistent with the content installed in the system. Any changes or modifications to the authorized system installation have been verified.

Information on software or hardware changes can be accessed through self-service inquiries on our company's official website or by contacting the authorized service center for consultation.

- - Product Performance Structure and Components: This product consists of an upper shell, display module, upper shell, lower shell, embedded needle printer, scanning module, dust cover, and power adapter.
- - Scope of Application: This product is suitable for the rapid monitoring of the survival of *Geobacillus stearothermophilus* spores and *Bacillus atrophaeus* spores in rapid biological indicators monitoring the sterilization effects of low-temperature plasma sterilization, pressure steam sterilization, low-temperature steam formaldehyde sterilization, or ethylene oxide sterilization.
- - Contraindications: None.
- - Warranty Period: 1 year.
- - Special Storage Conditions and Methods: None.
- - Monitoring Principle: The Automatic Bio Reader is based on the biological indicators. It utilizes the reaction between the metabolites of *Geobacillus stearothermophilus* and *Bacillus atrophaeus* in the process of growth and reproduction with specific components of the culture medium. The reaction products can produce a fluorescent effect under ultraviolet irradiation. Fluorescence monitoring is performed using a photosensitive receiver sensor. Based on the strength of the detected fluorescence, the concentration of specific metabolites can be rapidly determined, thereby indicating the survival status of the spores.

Table of Contents

1. Overview	1
1.1. Product Features	1
1.2. Main Purpose and Scope of Application	1
1.3. Body Code	2
2. Safety Precautions	2
2.1. Warranty Period	2
2.2. General Safety Instructions	2
2.3. Common Misuses or Errors	4
2.4. Special Precautions	4
3. Structural Features and Working Principle	4
3.1. Working Principle	4
3.2. Overall Structure	5
4. Technical Characteristics	6
4.1. Main Performance	6
4.2. Technical Parameters	8
4.3. Symbol Explanation	9
5. Use and Operation	10
5.1. Preparation and Inspection Before Use	10
5.2. Safety and Security Measures Before and During Use	11
5.3. Operating Instructions and Notes	11
5.4. Printing Record Explanation	18
5.5. Built-in Printer Explanation	19
6. Troubleshooting Guide	23
7. Maintenance and Repair	24
7.1. Daily Maintenance, Care, and Calibration	24
7.2. Maintenance and Guarantee During Long-Term Disuse	24
8. Transportation and Storage	25
8.1. Transportation Precautions	25

8.2. Storage Conditions, Storage Period, and Notes	25
9. Unboxing and Inspection	25
9.1. Inspection Contents	25
10. Environmental Protection and Others	25
11. Operation Process of Connecting Computer & View Records.....	26

Automatic Bio Reader User Manual

1. Overview

1.1. Product Features

1.2. Main Purpose and Scope of Application

The Automatic Bio Reader (hereinafter referred to as "the device") is used for the rapid and effective monitoring of the sterilization processes of low-temperature plasma sterilization with hydrogen peroxide, pressure steam sterilization, low-temperature steam formaldehyde sterilization, or ethylene oxide sterilization performed in medical equipment. It requires the use of rapid biological indicators for monitoring the effectiveness of low-temperature plasma sterilization with hydrogen peroxide, pressure steam sterilization, low-temperature steam formaldehyde sterilization, and ethylene oxide sterilization.

The device is designed for constant temperature incubation monitoring of rapid biological indicators. The fluorescence changes in the indicator can be read within 20/60/180 minutes for low-temperature plasma sterilization with hydrogen peroxide, pressure steam sterilization, and low-temperature steam formaldehyde sterilization, and within 180 minutes for ethylene oxide sterilization. The final negative/positive culture results are automatically obtained.

The device also accommodates the application demand for visual pH color interpretation. It allows continuous incubation of special indicators for 24 to 48 hours, with the final negative/positive culture results determined by visual pH color changes. However, compared to visual pH color interpretation, the fluorescence intensity interpretation method has the advantages of high sensitivity, rapid response, and small errors. After obtaining rapid fluorescence change interpretation results, it is not recommended to continue incubation to obtain visual pH color change results.

The device does not support the monitoring of sterilization results of other indicators outside of rapid biological indicators specifically for low-temperature plasma sterilization with hydrogen peroxide, pressure steam sterilization, low-temperature steam formaldehyde sterilization, or ethylene oxide sterilization.

1.3. Body Code

For effective identification, the device is equipped with a unique body code, which is stored internally.

2. Safety Precautions

2.1. Warranty Period

The device is designed for a safe use period of 5 years. The company promises free repairs within 1 year from the date of purchase based on the purchase invoice date. If there is no purchase invoice, the product's factory date is used for calculation.

2.2. General Safety Instructions

- 1) Before using the device for the first time, all operators should carefully read this user manual, especially the sections concerning safety provisions. The device should be operated by personnel familiar with its operation.
- 2) The device is for indoor use only.
- 3) If the device is damaged or not working properly, refer to the user manual for troubleshooting or contact the after-sales service center for consultation. Do not attempt to solve faults blindly.
- 4) After removing the DC power plug, confirm that the power plug and power adapter match the device before reinserting. Do not use a power adapter that does not match the device.
- 5) Prioritize the use of the power cord provided with the device. Do not

use uncertified power cords.

- 6) Do not spill liquids on the device externally or internally. Do not immerse the device in liquids.
- 7) Do not open the outer shell of the device.
- 8) Clean the device using the recommended methods and steps in this user manual.
- 9) Before cleaning and maintenance, the device must be disconnected from power. Do not perform cleaning or other maintenance operations while the device is powered.
- 10) If the indicator is treated with high temperature (e.g., steam) sterilization, it should be allowed to cool to room temperature (can be cooled by placing it in the air for 10-15 minutes) before being used. Do not shake or crush the indicator vigorously before effective cooling.
- 11) Ensure that the indicator has cooled to room temperature before inserting it into the monitoring position of the device.
- 12) When activating the indicator by crushing, wear protective goggles and gloves.
- 13) Use the recommended method in this user manual for crushing the indicator. Do not attempt to crush the indicator by squeezing it directly with your fingers.
- 14) Do not roll the indicator between your fingers to avoid wetting the spore carrier. Do not open the indicator cap.
- 15) Do not expose the device to direct sunlight or strong incandescent light. Keep it away from areas where direct sunlight or strong incandescent light may occur.
- 16) Do not expose the device to strong electromagnetic fields. Keep it away from any devices that may generate strong electromagnetic fields.
- 17) Avoid touching, removing, rotating, or replacing the indicator during the cultivation process until the cultivation result (+/-) is displayed on the display panel. Do not change the monitoring position.

- 18) Ensure smooth cultivation process. Do not place the device on a vibrating table or edge of a table during cultivation.

2.3. Common Misuses or Errors

- 1) Using power that does not match the device. Failure to carefully check the power plug and power adapter before reinserting the DC power plug, and using an incorrect power adapter for power supply.
- 2) Vigorously shaking the indicator before cooling.
- 3) Inserting the indicator into the device before cooling.
- 4) Crushing the indicator before cooling.
- 5) Failure to wear protective goggles or gloves during crushing.
- 6) Removing, moving, or rotating the indicator during cultivation.
- 7) Cultivating the indicator on a vibrating table.
- 8) Storing the indicator together with other fluorescent materials, causing contamination of the indicator.

2.4. Special Precautions

- 1) In the event of temporary power failure during cultivation, the cultivation must be restarted after inserting a new rapid biological indicator for monitoring. Interrupted cultivation cannot be continued.
- 2) During cultivation, efforts should be made to maintain stability. If it is necessary to move the device, it can be moved slightly without disconnecting power. Ensure that the device remains stable during movement.

3. Structural Features and Working Principle

3.1. Working Principle

The device utilizes the reaction between the metabolites of *Geobacillus stearothermophilus*/ *Bacillus atrophaeus* and specific components of the culture medium during the growth and reproduction process to achieve

rapid determination of the concentration of specific metabolites based on the detected fluorescence intensity, thereby determining the survival status of the spores.

3.2. Overall Structure

Diagram of Overall Structure

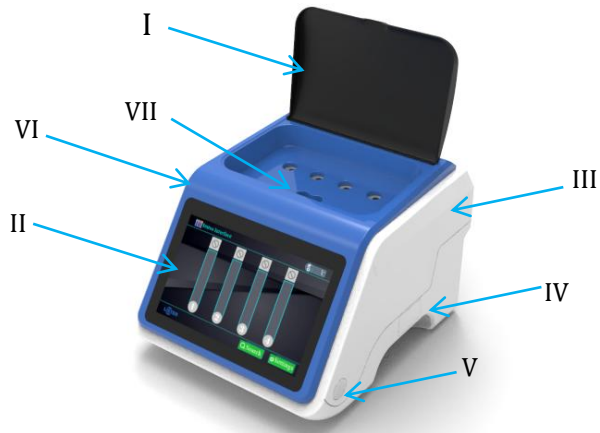

Figure 1

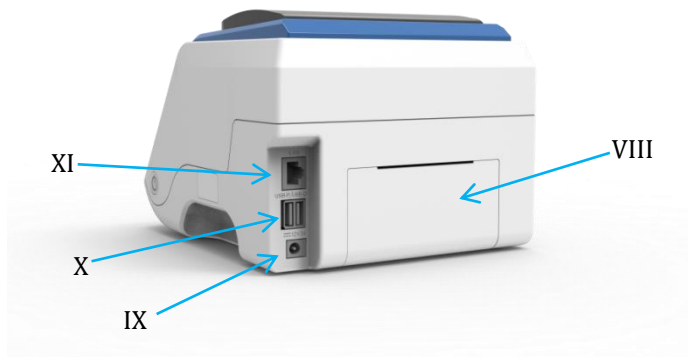
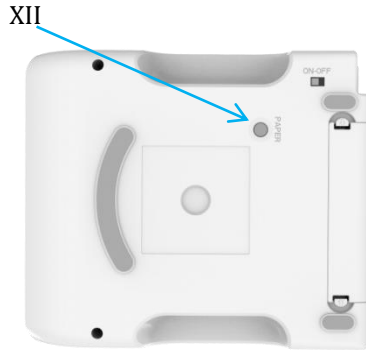

Figure 2



- | | |
|---------------------|------------------------|
| I. Dust Cover | VII. Crushing Hole |
| II. Display Module | VIII. Printing Module |
| III. Lower Shell | IX. DC Power Socket |
| IV. Scanning Window | X. USB-D Port |
| V. Power Button | XI. RJ45 Network Port |
| VI. Upper Shell | XII. Feed Paper Button |

4. Technical Characteristics

4.1. Main Performance

1) Rapid Detection

Judgment of cultivation results within 20 minutes:

- 20-minute biological indicators: *Low-Temperature Hydrogen Peroxide Plasma Sterilization / Steam Sterilization/ Low-Temperature Formaldehyde Sterilization;*
- 60-minute biological indicators: *Low-Temperature Hydrogen Peroxide Plasma Sterilization / Steam Sterilization/ Low-Temperature Formaldehyde Sterilization;*
- 180-minute biological indicator: *Low-Temperature Hydrogen Peroxide Plasma Sterilization / Steam Sterilization/ Low-Temperature Formaldehyde Sterilization / Ethylene Oxide sterilization.*

2) Data Processing and Storage

After cultivation, the cultivation results are automatically saved and can be easily viewed on the device. Up to 10,000 cultivation result records can be stored. The data can be exported through the USB port or Ethernet interface on the device for users to query, edit, and print historical records on other devices.

3) Sterilization Information Traceability System

During the sterilization process, relevant information such as biological indicators and operators can be inputted. This information can be included in the saved final cultivation results and can be queried, edited, and printed through the "Data Processing and Storage" function.

4) Visualization

Interaction is conducted via a touchscreen, supporting a visual user interface.

5) Multi-directional Alarm Prompt

Alarm prompts are provided through both beeping and on-screen display, allowing operators to comprehensively understand real-time cultivation information.

6) Quick Switch between Chinese and English Interfaces

Both Simplified Chinese and English interfaces are developed, supporting quick switching between the two interfaces.

4.2. Technical Parameters

Table1: Operating Parameters

Power Supply Item	Power Requirements
Input	AC: 100~240V, 1.5A, 50/60Hz
Output	DC: 12V, 300mA~6000mA
Operating Temperature	5°C~35°C
Operating Humidity (RH)	≤95% (no condensation at >85%)
Operating Atmospheric Pressure	700~1060 HPa
Operating Voltage	DC 12V
Operating Current	[max] DC 1.8A
Storage Temperature	-10°C~45°C
Storage Humidity (RH)	10%~90% (non-condensing)
Overvoltage Category	Category II
Pollution Degree	2

Table 2: Main Parameters

Item	Parameters	Remarks
Cultivation Time	≤20/60 minutes /≤180 minutes	Hydrogen peroxide low-temperature plasma sterilization: 20/60/180 minutes; Pressure steam sterilization: 20/60/180 minutes; Low-temperature steam formaldehyde sterilization: 20/60/180 minutes; Ethylene oxide sterilization: 180 minutes
Dimensions (W*D*H)	200mm×170mm×140mm	
Net Weight	1.2 kg	Excluding power adapter

Gross Weight	1.5 kg	Including power adapter and foam filler
Cultivation Holes	4	
Screen Size	5 inches	Touchscreen
Screen Resolution	800×480	TFT, 2.56 million colors
Cultivation Temperature	58±2°C 37±2°C	Temperature can be selected according to the indicator type
Built-in Printer	Real-time printing of cultivation results	Paper roll size Φ30×57mm

4.3. Symbol Explanation



: Fault indication, indicating a fault in the device accessories or control system. Refer to "**6. Troubleshooting Guide- Table 3: Fault Modes and Solutions**" for details.



: Fault indication, indicating an error in operation or cultivation detection. Refer to "**6. Troubleshooting Guide- Table 3: Fault Modes and Solutions**" for details.



: Positive result, indicating a positive fluorescence interpretation result in cultivation results.



: Negative result, indicating a negative fluorescence interpretation result in cultivation results.



: Cultivation in progress...



: Warning, error.



: Channel status is empty, indicator can be inserted.



: Scanning Mode OFF



: Scanning Mode ON

5. Use and Operation

5.1. Preparation and Inspection Before Use

1) Before turning on the device, the following preparations should be made:

- Confirm that there are no indicators in each cultivation hole before connecting the power.
- Ensure that the environment temperature and humidity meet the requirements, and there is no vibration or strong light exposure.
- Use the original qualified power adapter.

2) Initialization check:

After turning on the device, observe whether the display screen displays error codes. If so, troubleshoot according to "6. System Fault Troubleshooting Table 3: Fault Modes and Solutions" in this manual. If not, wait for 20~30 minutes for preheating to complete before cultivation and testing.

3) Preparation of indicators before cultivation:

- After wearing protective glasses, press the cap of the biological indicator.
- Crush the indicator in the indicator crushing hole on the device or use a special clamp to crush the glass ampoule containing the culture medium.
- Hold the end of the indicator cap and knock on the table 3 to 4 times to ensure that the culture medium flows to the bottom of the bacterial slice.
- Insert the rapid biological indicator into the cultivation hole.

5.2. Safety and Safety Protection Before and During Use

Incorrect operation may endanger personnel or equipment safety. Therefore, strict compliance with the following specifications is required during use:















- 1) It is strictly forbidden to crush or handle the indicator excessively before it cools down to prevent the glass ampoule from bursting.
- 2) Wear protective glasses and gloves when removing the indicator from the sterilizer.
- 3) Wear protective glasses when crushing the indicator. Hold the end of the cap to crush the indicator at the crushing hole.
- 4) It is strictly forbidden to use fingers for the above crushing operation, and do not roll the indicator between your fingers to avoid cuts.
- 5) Pay attention to preventing the device from falling during the indicator crushing process.

5.3. Operating Procedures and Precautions



1) Normal Operation Procedure for this Device:

- a. Turn on the AC power and check if the power adapter indicator light is on.
- b. Do not insert any indicator into the cultivation hole, close the dust cover. Connect the output end of the power adapter to the device, press the power button to turn it on.
- c. After briefly displaying the startup animation (self-checking, lasts about 10 seconds), enter the "**Mode Selection**" interface shown in **Figure 3**. Select the mode according to the type of indicator to be cultivated, and enter the startup preheating interface. After preheating for about 20 minutes, enter the "**Status Interface**" shown in **Figure 4**. If you need to set up this device, click on the upper right corner "**Settings**", enter the "**Main Interface**" shown in **Figure 5**, where you can enter information, query historical records, set

permissions, basic settings, and view machine information. Click " Back" to return to the "**Status Interface**" shown in **Figure 4**.

- d. Click the " Information Input" button to enter the "**Sterilizer Information Input**" interface shown in **Figure 6**, enter the information of the sterilization equipment in the venue, click " Next" to enter the "**User Information Input**" interface shown in **Figure 7**, enter the username or user number, and click " Save" to permanently save the relevant information. Click " Back" to return to the main interface.
- e. Click the " Search" button to enter the "**Historical Records Query**" interface shown in **Figure 8**. Click " Print" to print the historical records of the current page. Click " Previous" or " Next" to switch pages. Click " Feed" to check the printer paper feed status.
- f. Click the " Permission Settings" button to enter the "**Permission Settings**" interface shown in **Figure 9**. Click on the permission settings that need to be enabled, enter the "**Password Input**" interface shown in **Figure 10**, and enter the permission password to make the settings change.
- g. Click the " Settings" button to enter the "**Basic Settings**" interface shown in **Figure 11**. In this interface, you can switch languages, set the time, printer status, background brightness, etc. After setting, click " Save" button.
- h. Click the " About" button to enter the "**Machine Information**" interface shown in **Figure 12**, where you can view relevant information of the machine. Click " Next" to enter the "**Attention**" interface as in **Figure 13**, where you can view operational precautions and alarm message analysis.



2. Cultivation Operation Steps:

- a. Within 3 minutes of crushing the indicator, as shown in **Figure 4 "Status Interface"**, the numbers at the bottom of the display screen represent the numbers of each cultivation hole (①, ②, ③, ④), marking each cultivation hole. Click on the channel number at the bottom of the status interface, enter the scanning mode, align the indicator with the QR code on the right scanning window, when the alarm sounds, the channel status changes to blue, indicating that the cultivation channel is opened. Insert the indicator into the cultivation hole, and the system will automatically enter the cultivation mode according to the type of QR code.
- b. As shown in **Figure 14 "Cultivation Status"** interface, the light cyan bar below the number indicates the remaining cultivation time of each cultivation channel. In the initial stage of cultivation, the cyan bar is high, and in the later stage of cultivation, the cyan bar is low. The black number below the bar indicates the remaining cultivation time of each cultivation channel in minutes.
- c. In the interface shown in **Figure 14 "Cultivation Status"**, the symbols at the bottom indicate the current cultivation status of each channel. For specific meanings of each symbol, please refer to the **"4.3 Symbol Explanation"** section of this user manual.
- d. In the interface shown in **Figure 14**, when the channel is in cultivation status, click on the number in the middle of the display screen (①, ②, ③, ④), you can enter the **"Traceability Information Input"** interface shown in **Figure 15**. The first two parameters (cultivation record number, cultivation channel number) are automatically generated by the system. After entering the other four items of retrospective information as needed, click the " " button. In the pop-up input box, enter another channel number, and the same retrospective information will be automatically entered into the target channel. After completion, please click the " " button to save the information and press the " " button to return to the **"Cultivation Status"** interface shown in **Figure 14**.



- e. When in the "**Traceability Information Input**" interface as shown in **Figure 15**, if sterilizer information needs to be entered, simply select the "**Sterilizer Selection**" interface shown in **Figure 16**. The sterilizer number and related information are pre-entered and saved in the "**Information Entry**" interface shown in **Figure 6**.

5. Others (Permission Settings Interface):



- a. **Network Settings:** First enter the "**Permission Settings**" interface shown in

Figure 9, click " " to input the permission password "0260011" to enter the "**Network Settings**" interface shown in **Figure 17**, set the device's IP address and gateway address parameters to the same LAN address within the LAN, click " ", enter the "**Parameter Change**" interface shown in **Figure 18**, click " " button to restart the device; connect one end of the network cable to the computer and the other end to the device, open the computer browser, enter the device IP address/R00X (R00X: /R is a fixed compilation code, 00X is the number of items to be exported, with the latest data as the first item).

- b. **Delete Cultivation Records:** First enter the "**Permission Settings**" interface

shown in **Figure 9**, click " " to input the permission password "0260013" to enter the "**Delete Cultivation Record Warning**" interface shown in **Figure 19**, click " " button, the system will automatically restart to complete the cultivation record deletion operation.

- c. **Restore Factory Settings:** First enter the "**Permission Settings**" interface

shown in **Figure 9**, click " " to input the permission password "0260015" to enter the "**Factory Reset Warning**" interface shown in **Figure 20**, click " " button, and the system will automatically restore to factory settings.

- d. Scan Module Status: First enter the "**Permission Settings**" interface shown in **Figure 9**, click "**Scan ON/OFF**" to enter the warning interface to turn on or off the scan module, and make the settings selection according to the prompts.

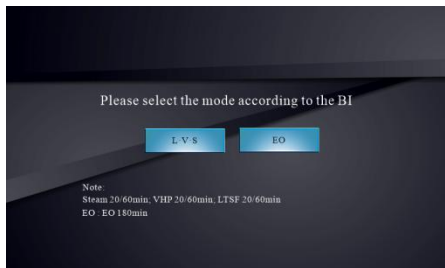

Figure 3: Mode Selection

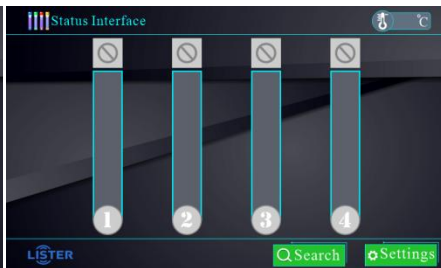

Figure 4: Status Interface

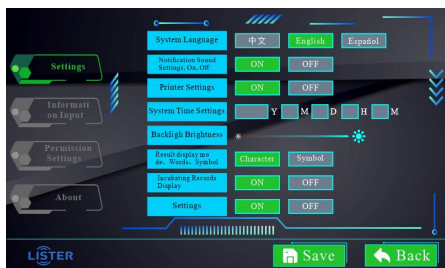

Figure 5: Main Interface

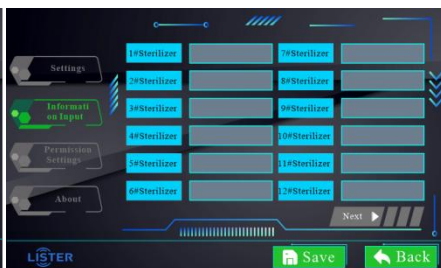

Figure 6: Sterilizer Information Input

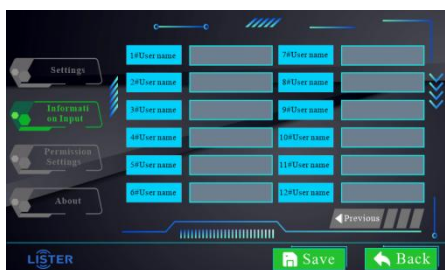

Figure 7: User Information Input



Figure 8: History Record Query

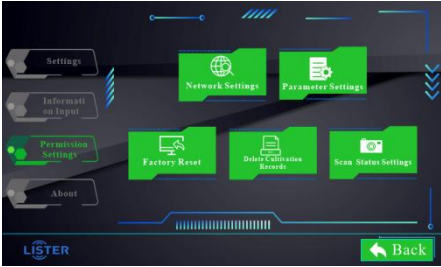

Figure 9: Permission Settings

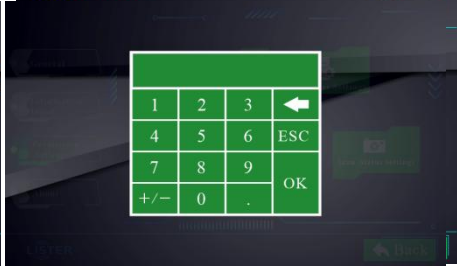

Figure 10: Password Input



Figure 11: Basic Settings



Figure 12: About This Machine

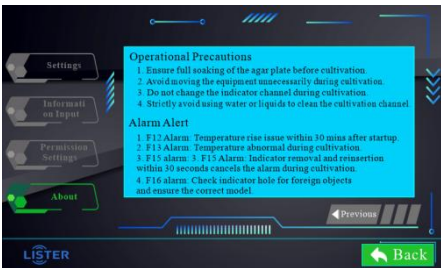

Figure 13: Attention

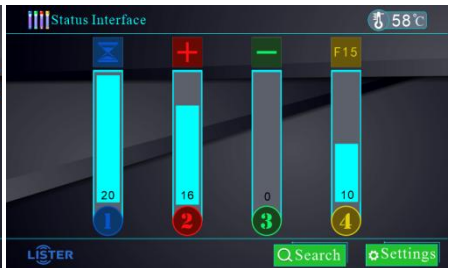

Figure 14: Cultivation Status

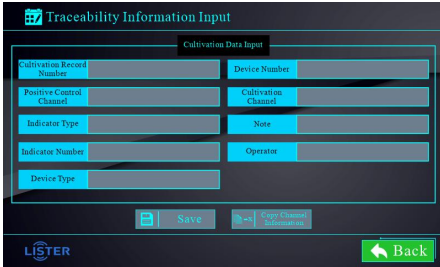

Figure 15: Traceability Information Input

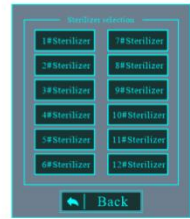

Figure 16: Sterilizer Selection



Figure 17: Network Settings

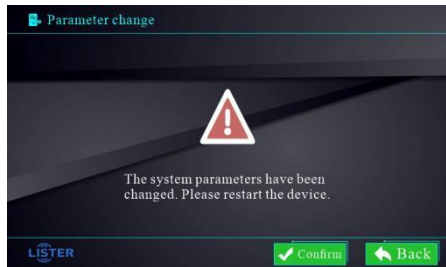

Figure 18: Parameter Change

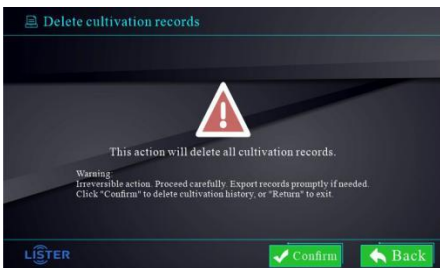

Figure 19: Delete Cultivation Record Warning

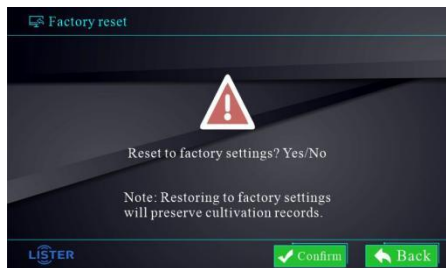

Figure 20: Factory Reset Warning

Precautions:

- *When using for the first time each day, it is necessary to test an unexposed indicator to confirm the viability of spores and the normal operation of the automatic reading machine. The unexposed indicator serves as a Positive Control.*
- *During the cultivation process, if it is necessary to remove and check the indicator, it must be reinserted within 30 seconds after removal. Otherwise, the current cultivation will be automatically canceled.*

5.4 Printing Record Instructions:

Incubation Record No.		
1	Reader No.	220301010210800
2	Incubation End Date	2024-02-24 18:00
<hr/>		
3	Incubation Record No.	20220224001
4	Incubation Channel	1
5	Positive Control	2
6	Channel Incubation Duration	15min
7	Cultivation Result	+(Positive)
8	Device Type	Steam
9	Device Number	001
10	Indicator Number	001
11	Indicator Type	Steam 60min
12	Operator	001
<hr/>		
13	Signature	
14	Date	
15	Note	

- 1) Device serial number
- 2) End date of current channel cultivation
- 3) Incubation record number (auto-generated by the device)
- 4) Incubation channel number
- 5) Positive control channel number
- 6) Time taken for Incubation
- 7) “+”Positive result . (“-”Negative result)
- 8) Sterilizer type (based on the indicator type)
- 9) Sterilizer serial number
- 10) Indicator number
- 11) Indicator type
- 12) Username or employee ID
- 13) Operator signature area
- 14) Signature date area
- 15) Remarks area (can paste indicator label)

5.5 Built-in Printer Instructions:

1) Explanation of **Printer Paper Jam**:

- If the printer encounters a paper jam status, ensure that the device is powered on. First, remove the left side printer compartment cover of this device.
- Gently pull the printer out from the compartment. Click the "**Feed**" button on the "**Historical Record Query**" Interface as shown in **Figure 21** or press the "**Paper Feed**" button at the bottom of the printer as shown in **Figure 22** to activate the printer's automatic paper feeding mode.
-

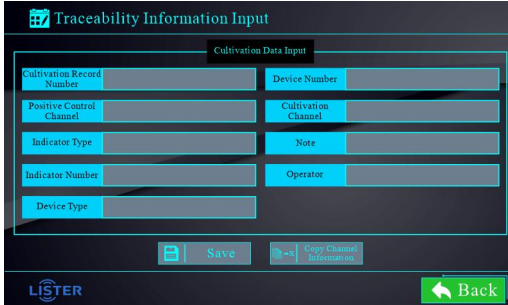

The screenshot displays a software interface titled "Traceability Information Input". At the top, there is a sub-header "Cultivation Data Input". Below this, a form contains several input fields arranged in two columns. The left column includes fields for "Cultivation Record Number", "Positive Control Channel", "Indicator Type", "Indicator Number", and "Device Type". The right column includes fields for "Device Number", "Cultivation Channel", "Note", and "Operator". At the bottom of the form, there are two buttons: a "Save" button and a "Apply Channel Information" button. Below the form, the "LISTER" logo is visible on the left, and a green "Back" button with a left-pointing arrow is on the right.

Figure 21: Historical Record Query

- Check if the paper is feeding normally. If not, gently pull the printing paper outwards for about 100 millimeters and observe if the paper feeding returns to normal.
- If the paper feeding returns to normal, press the printer back into the printer compartment, click the paper feeding button to turn off the automatic paper feeding mode, and close the printer compartment cover.
- If the paper jam issue persists after the above steps, first attempt to replace the printing paper and try again. If the issue persists, check if the printer is functioning properly. If none of the above reasons apply, please contact the supplier for after-sales service.

2) Printer Paper Replacement Instructions:

- ① Ensure that the device is powered on. Flip the machine and remove the left side printer compartment cover as shown in **Figure 22**.

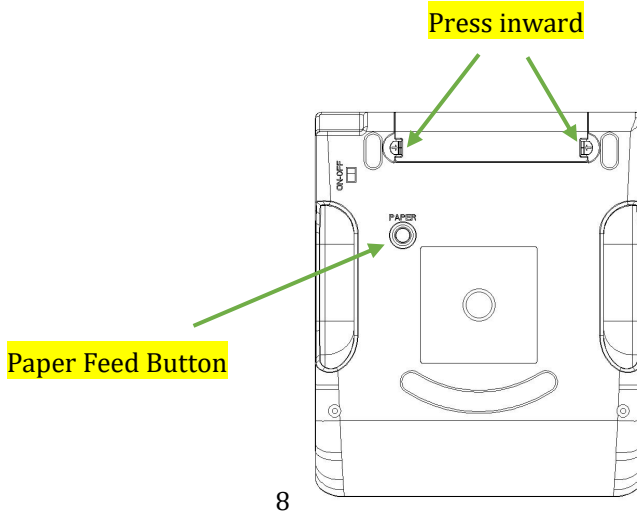

Figure 22: Device flipping

- ② Gently pull the printer out of the printer compartment as shown in **Figure 23**;

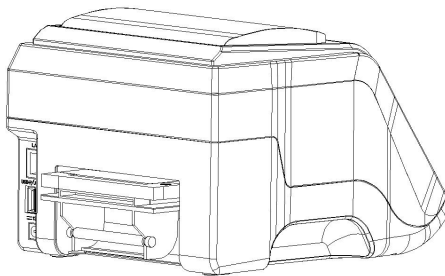

Figure 23: Pulling out the printer from the printer compartment.

③ Remove the paper roll holder, and insert it into the designated paper roll as shown in **Figure 24**;

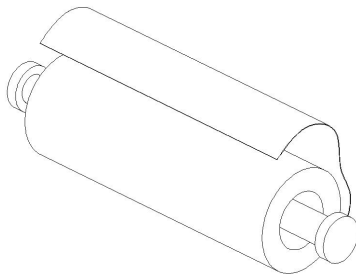

Figure 24: Roll Shaft & Print Paper

④ Insert the paper roll shaft into the printer, as shown in **Figure 25**;

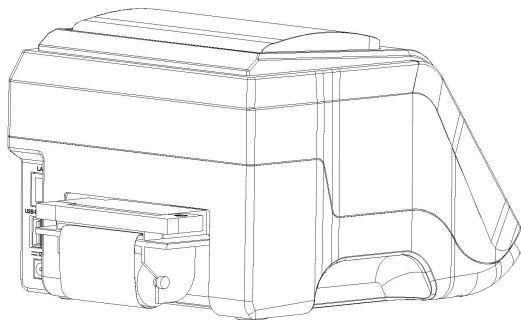

Figure 25: Insert the paper roll shaft into the printer.

⑤ Click the "**Feed**" button on the "**Historical Record Query Interface**" as shown in **Figure 21**, or press the "**Paper Feed**" Button located at the bottom of the printer as depicted in **Figure 22**, to activate the automatic paper feeding mode of the printer.;

⑥When the paper smoothly passes through the paper feed slot and comes out, as shown in **Figure 26**;

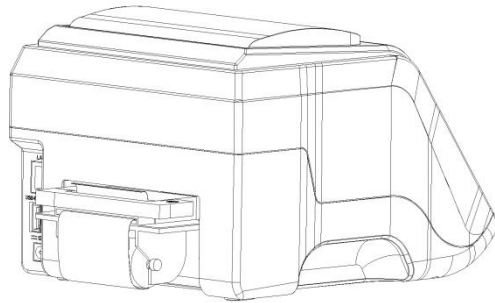

Figure 26: Printer ejecting paper normally

⑦Click on the "**Feed**" button on the "**Historical Record Query**" interface as shown in **Figure 21** or click on the mechanical "**Paper Feed**" button at the bottom of the printer as shown in **Figure 22** to deactivate the automatic paper feeding mode. Then, push the printer back into the printer compartment, close the printer cover, and click on the "**Feed**" button on the "**Historical Record Query**" interface in **Figure 21** to check if the printer is ejecting paper correctly and if the printed data is complete and accurate.

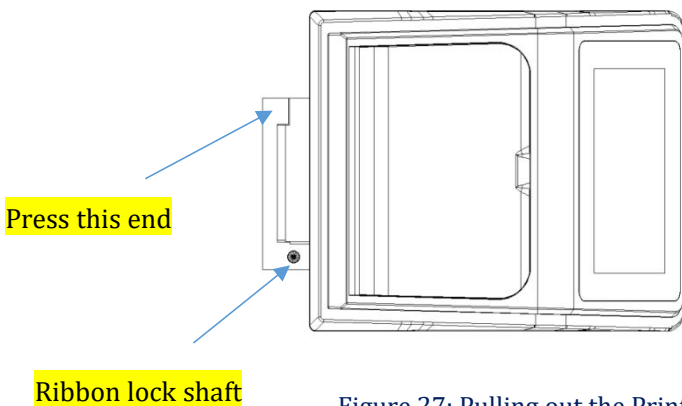

Figure 27: Pulling out the Printer

3) Printer Ribbon Replacement Instructions

- a. Pull out the printer from the printer compartment following the procedure in **section 5.5.1**;
- b. Press on one end of the ribbon as shown in **Figure 27**;
- c. Remove the ribbon, take out the new ribbon from the packaging, and install it in the ribbon loading position;
- d. Use your fingertips to rotate the ribbon locking shaft to secure the ribbon;
- e. Reassemble the printing paper, press the printer back into the printer compartment;
- f. Test whether the printer ribbon is functioning properly.

6、Troubleshooting Guide

Table 3: Fault Modes and Solutions

Code	Fault Mode	Solution
	Display screen not lit Display screen showing abnormality	Restart the device Change the AC socket Replace the power adapter
F12	Temperature rise abnormality, the device does not reach the set constant temperature range within 30 minutes after startup	Disconnect power supply Check if the power adapter is correct
F13	Temperature constant abnormality, temperature exceeds the constant temperature range during normal cultivation process	Replace the power adapter
F14	Startup environment check, environment light intensity does not meet the equipment's usage range	Move the device indoors Avoid using in strong light
F15	During cultivation, the indicator is removed	Reinsert the same indicator within 30 seconds
F16	Insertion of unsuitable indicator	Check for foreign objects in the indicator detection hole Check if the indicator is the specified model

7. Maintenance and Repair

7.1 Daily Maintenance and Calibration

Warning: Before cleaning and maintaining the equipment, the power supply must be disconnected. Do not perform maintenance or cleaning while the equipment is powered on.

- Keep the equipment clean, especially ensure that there are no foreign objects in the detection channel holes. Regular inspections of the equipment are necessary to ensure cleanliness.
- Wipe the equipment surface with a damp cloth dipped in mild detergent.
- Use a cotton swab dipped in a small amount of alcohol to clean the detection channel holes. Note: Do not use excessive alcohol, as it may flow into the device through the detection channel holes and affect device performance.
- Prohibit the use of organic solvents to wipe the equipment surface.
- Do not disassemble the equipment or clean the internal parts.
- If internal maintenance is required, please contact the after-sales service center.

7.2 Maintenance and Guarantee During Long-term Disuse

- If the equipment is not used for an extended period, perform the daily maintenance mentioned above, then pack the equipment in its original packaging and store it in an environment with a temperature of 20°C to 40°C and Relative Humidity of 30% to 60%.
- Before using the equipment after prolonged storage, calibrate the the light source (i.e., Ultraviolet light).

8. Transportation and Storage

8.1 Transportation Precautions

- Avoid exposure to sunlight and rain.
- Store with the front side facing up.
- Handle with care to prevent dropping.
- Stack no more than 4 layers high.

8.2 Storage Conditions, Shelf Life, and Precautions

- Temperature: 20°C to 40°C
- Relative Humidity: 30% to 60%
- Shelf Life: 5 years (can be stored for up to 3 years without use)
- Regular inspections are recommended.

9. Unboxing and Inspection

9.1 Inspection Checklist

- Check for missing items according to the packing list.
- Inspect the equipment for any damage.
- Verify the parameters of the power adapter.
- Power on the device and check for any operational abnormalities.

10. Environmental Protection and Other Matters

- After prolonged use, the equipment may involve biological hazards, it's suggested to disinfect the Reader by ethylene oxide sterilization after a long term use.
- Please collect the used biological indicators centrally and dispose of them according to local medical waste disposal regulations.
- If a positive result occurs during testing, the instruments from the same batch of sterilization must undergo sterilization again.

➤ Operation Process of Connecting Computer & View Records

1. Prepare a **dual-ended USB data cable**.
2. Connect one end of the cable to the computer and the other end to the ***USB-D Port*** on the device, as shown in **Figure 28**.

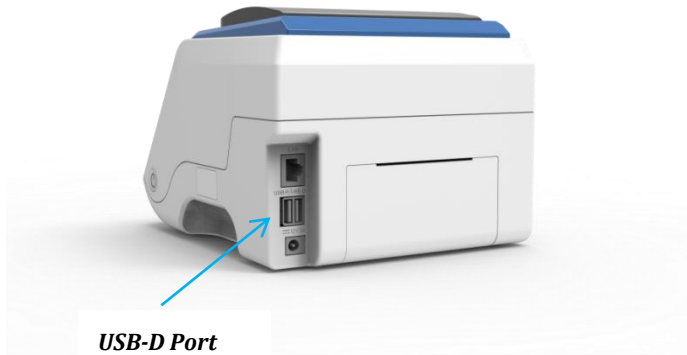

Figure 28

3. Open the "READER" software, where you can switch between Chinese and English languages. (Please request the Software Download File from the supplier.)
4. Click the ***"Refresh"*** and ***"Access to record"*** button.
5. Click the ***"Open"*** button.
6. Click the ***"Export Report"*** button.

Manufacturer: LISTER BIOMEDICAL CO., LTD.

ADD: BUILDING 2,NO.72 SHENGLI ROAD,YIXIU, ANQING,ANHUI,CHINA

Contact: 0556-5689070

Web: www.listerbiomed.com